

KETTLER

HKS-SELECTION

Montageanleitung Crosstrainer „Unix M“

Art.-Nr. 07650-000



Technical specifications and assembly information for the Kettler Unix M cross-trainer:

- Dimensions:
 - A: 138 cm
 - B: 58 cm
 - C: 155 cm
- Weight: 60,8 kg
- Max. user weight: max. 150 kg
- Assembly time: ~30 - 45 Min.

Country codes for regional versions:

- 2-3 (D)
- 4-5 (GB)
- 6-7 (F)
- 8-9 (NL)
- 10-11 (E)
- 12-13 (I)
- 14-15 (PL)
- 16-17 (CZ)
- 18-19 (P)
- 20-21 (DK)
- 22-24 (RUS)

MADE IN GERMANY

Auf 100% Altpapier!

Abb. ähnlich



Please read these instructions carefully prior to carrying out assembly and using for the first time. They contain information which is important for your safety as well as for the use and maintenance of the appliance. Keep these instructions in a safe place for reference purposes, maintenance work and to assist you when ordering spare parts.

For Your Safety

RISK! While assembly of the product keep off children's reach (Choking hazard - contains small parts).

RISK! Any other use of the equipment is prohibited and may be dangerous. The manufacturer cannot be held liable for damage or injury caused by improper use of the equipment.

RISK! Instruct people using the equipment (in particular children) on possible sources of danger during exercising.

RISK! Incorrect repairs and structural modifications (e.g. removal or replacement of original parts) may endanger the safety of the user.

RISK! Heart rate monitoring systems may be inaccurate. Over exercise may result in serious injury or death. If you feel faint stop exercising immediately.

RISK! All electric appliances emit electromagnetic radiation when in operation. Please do not leave especially radiation-intensive appliances (e.g. mobile telephones) directly next to the cockpit or the electronic control system as otherwise values displayed might be distorted (e.g. pulse measurement).

WARNING! The training device should be used only for its intended purpose, i.e. for physical exercise by adult people.

WARNING! Before beginning your program of training, study the instructions for training carefully.

WARNING! Any interference with parts of the product that are not described within the manual may cause damage, or endanger the person using this machine. Extensive repairs must only be carried out by KETTLER service staff or qualified personnel trained by KETTLER.

- The training device has been designed in accordance with the latest standards of safety. Any features which may have been a possible cause of injury have been avoided or made as safe as possible.
- The training device corresponds with DIN EN 957 -1/-9, class HB.
- In case of enquiry, please contact your KETTLER dealer.

- **If the equipment is in regular use, check all its components thoroughly every 1–2 months. Pay particular attention to the tightness of bolts and nuts. This is particularly true for the attachment of grip strap, running plate and fastening of the handlebar and front tube.**
- Before beginning your program of exercise, consult your doctor to ensure that you are fit enough to use the equipment. **Base your program of exercise on the advice given by your doctor. Incorrect or excessive exercise may damage your health!**
- Before use, always check all screws and plug-in connections as well as respective safety devices fit correctly.
- Always wear suitable shoes when using.
- Our products are subject to a constant innovative quality assurance. We reserve the right to perform technical modifications.
- In choosing the location of the apparatus, ensure a sufficient safety distance from any obstacles. The apparatus must not be mounted in the immediate vicinity of main passageways (paths, doorways, corridors).
- Always observe the general safety rules and precautions for working with electrical equipment.
- The product is not suitable for use by persons weighing over 150 kg.
- Nobody may be in the moving range of a training person during training
- **This exercise machine may only be used for exercises indicated in the training instructions.**
- The surface on which the unit is placed must be firm and even. Place rubber or straw mats under it to deaden any noise or impacts. Only for appliances with weights. Avoid powerful oscillations of the dumbbells!
- When mounting the product please take the recommended torque information into account ($M = xx \text{ Nm}$).

Instructions for Assembly

RISK! Ensure that your working area is free of possible sources of danger, for example don't leave any tools lying around. Always dispose packaging material in such a way that it may not cause any danger. There is always a **risk of suffocation** if children play with plastic bags!

WARNING! Please note that there is **always** a danger of injury when working with tools or doing manual work. Therefore please be careful when assembling this machine.

- Ensure that you have received all the parts required (see check list) and that they are undamaged. Should you have any cause for complaint, please contact your KETTLER dealer.
- Before assembling the equipment, study the drawings carefully and carry out the operations in the order shown by the diagrams. The correct sequence is given in capital letters.
- The equipment must be assembled with due care by an adult person. If in doubt call upon the help of a second person, if

possible technically talented.

- The fastening material required for each assembly step is shown in the diagram inset. Use the fastening material exactly as instructed. The required tools are supplied with the equipment.
- Bolt all the parts together loosely at first, and check that they have been assembled correctly. Tighten the locknuts by hand until resistance is felt, **then use spanner to finally tighten nuts completely against resistance (locking device)**. Then check that all screw connections have been tightened firmly. **Attention:** once locknuts have been unscrewed they no longer function correctly (**the locking device is destroyed**), and must be replaced.
- For technical reasons, we reserve the right to carry out preliminary assembly work (e.g. addition of tubing plugs).

Handling the equipment

- Before using the equipment for exercise, check carefully to ensure that it has been correctly assembled.
- It is not recommended to use or store the apparatus in a damp room as this may cause it to rust. **Please ensure that no part of the machine comes in contact with liquids (drinks, perspiration etc.). This may cause corrosion.**
- The machine is designed for use by adults and children should not be allowed to play with it. Children at play behave unpredictably and dangerous situations may occur for which the manufacturer cannot be held liable. If, in spite of this, children are allowed to use the equipment, ensure that they are instructed in its proper use and supervised accordingly.
- The equipment is independent of revolutions per minute.
- A slight production of noise at the bearing of the centrifugal mass is due to the construction and has no negative effect upon operation. Possibly occurring noise during reverse pedalling result from engineering and are absolutely safe.
- The training device has a magnetic brake system.
- To operate correctly, the pulse function requires a minimum

voltage of 2,7 volts (only for computers working with batteries).

- Before beginning your first training session, familiarize yourself thoroughly with all the functions and settings of the unit.

Care and maintenance

- Damaged components may endanger your safety or reduce the lifetime of the equipment. For this reason, worn or damaged parts should be replaced immediately and the equipment taken out of use until this has been done. Use only original KETTLER spare parts.
- To ensure that the safety level is kept to the highest possible standard, determined by its construction, this product should be serviced regularly (once a year) by specialist retailers.
- Use for your regular cleaning, maintenance and care our appliance maintenance set (Article no. 07921-000) specifically licensed for KETTLER Sports apparatus and available from the Sport specialized trade.
- **Please ensure that liquids or perspiration never enter the machine or the electronics.**

List of spare parts page 36-38

When ordering spare parts, always state the full article number, spare-part number, the quantity required and the S/N of the product (see handling).

Example order: Art. no. 07650-000 / spare-part no. 67000653 / 2 pieces / S/N Please keep original packaging of this article, so that it may be used for transport at a later date, if necessary.

Goods may **only** be returned after prior arrangement and in (internal) packaging, which is safe for transportation, in the original box if possible. It is important to provide a detailed defect description / damage report!

Important: spare part prices do not include fastening material; if fastening material (bolts, nuts, washers etc.) is required, this should be clearly stated on the order by adding the words „with fastening material“.

Waste Disposal

KETTLER products are recyclable. At the end of its useful life please dispose of this article correctly and safely (local refuse sites).

KETTLER GB Ltd.

Kettler House, Merse Road
North Moons Moat

Redditch, Worcestershire B98 9HL

+44 1527 591901

+44 1527 62423

www.kettler.co.uk

Mail: sales@kettler.co.uk

KETTLER International Inc.

1355 London Bridge Road
Virginia Beach, VA 23453

+1 888 253 8853

+1 888 222 9333

www.kettlerusa.com

Messhilfe für Verschraubungsmaterial

- GB - Measuring help for screw connections
- F - Gabarit pour système de serrae
- NL - Meethulp voor schroefmateriaal
- E - Ayuda para la medición del material de atornilladura
- I - Misura per materiale di avvitanento

- PL - Wzornik do połączeń śrubowych
- CZ - Měřicí pomůcka pro materiál k přišroubování
- P - Auxiliar de medição para materiais de aparafusamento
- DK - Hjælp til måling af skruer
- RUS - Справка по определению размеров крепежных материалов

Beispiel
Ejemplas
Příklad

Exemples
Esemp
Eksempel





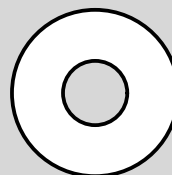
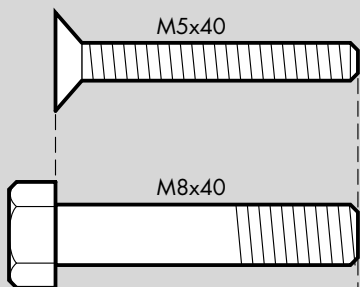

Exemples
Przykład
Примеры

Bij voorbeeld
Exemplo

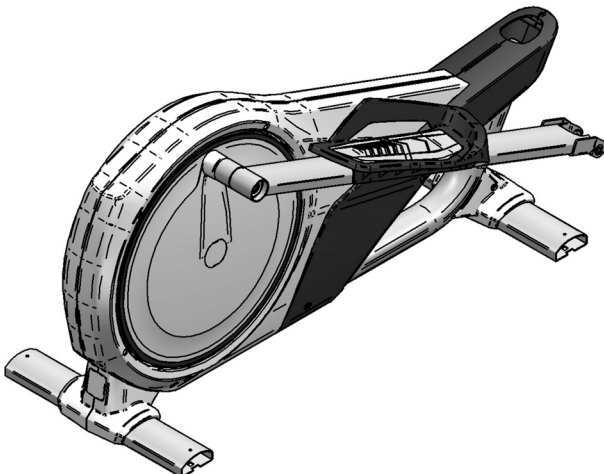
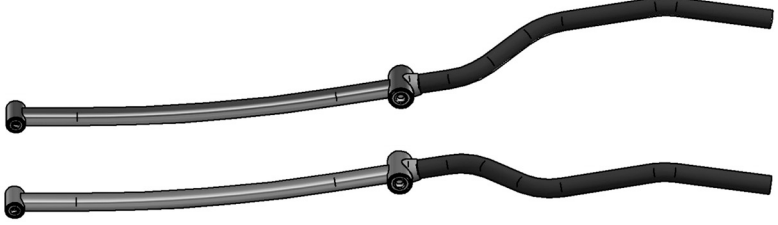
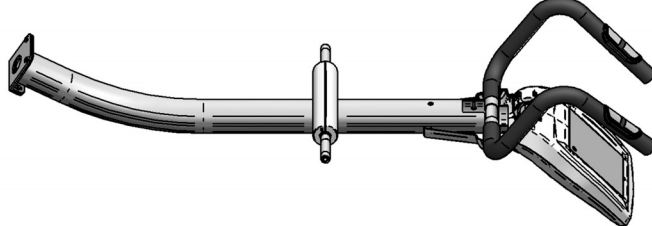



Checkliste (Packungsinhalt)

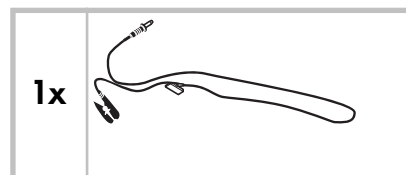

- GB - Checklist (contents of packaging) - F - Liste de vérification (contenu de l'emballage) - NL - Checklijst (verpakkinginhoud)
- E - Lista de control (contenido del paquete) - I - Lista di controllo (contenuto del pacco) - PL - Lista kontrolna (zawartość opakowania)
- CZ - Kontrolní seznam (obsah balení) - P - Lista de verificação (conteúdo da embalagem) - DK - Checkliste (pakkens indhold)
- RUS - Контрольный список

	1x	
	1x	
	1x	
	1x	
	1x	
	1x	
	1x	
	1x	

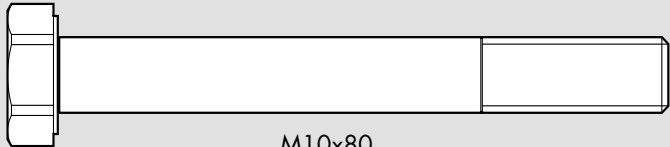
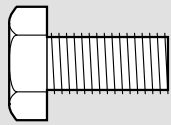
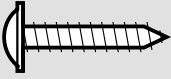

Checkliste (Packungsinhalt)

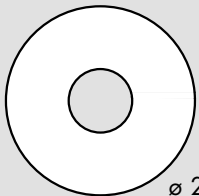
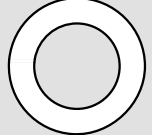
2x		M10x80
6x		M8x16
3x		3,9x19
3x		4x35

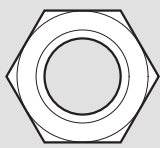
2x		ø 25x8,4
4x		ø 18x11,3
4x		ø 16x8,3
2x		M10

- D - Benötigtes Werkzeug - Gehört nicht zum Lieferumfang.
- GB - Tools required - Not included.
- F - Outils nécessaires - Ne fait pas partie du domaine de livraison.
- NL - Benodigd gereedschap - Is niet bij de levering inbegrepen.
- E - Herramientas necesarias - No forma parte del volumen de entrega.
- I - Strumenti necessari - Non in dotazione alla fornitura.
- PL - Narzędzi - Nie należy do zakresu dostawy.
- CZ - Nářadí potřebné - Nepatří do rozsahu dodávky
- P - Ferramentas necessárias - Não está incluído nas peças fornecidas
- DK - Værktøjer kræves - Er ikke inkluderet i leveringsomfanget.
- RUS - Необходимый инструмент - не включены.

1

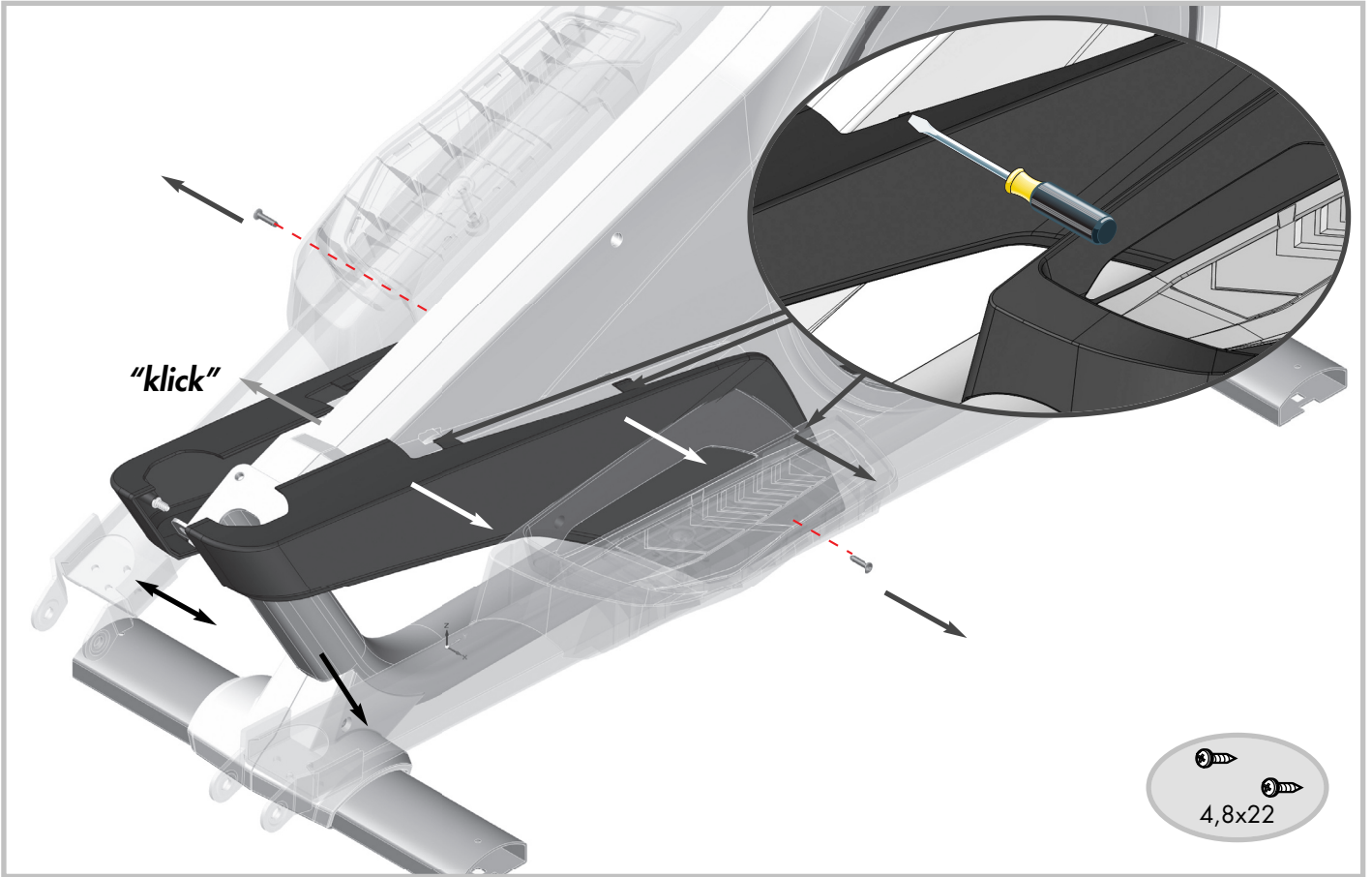
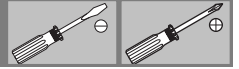

2

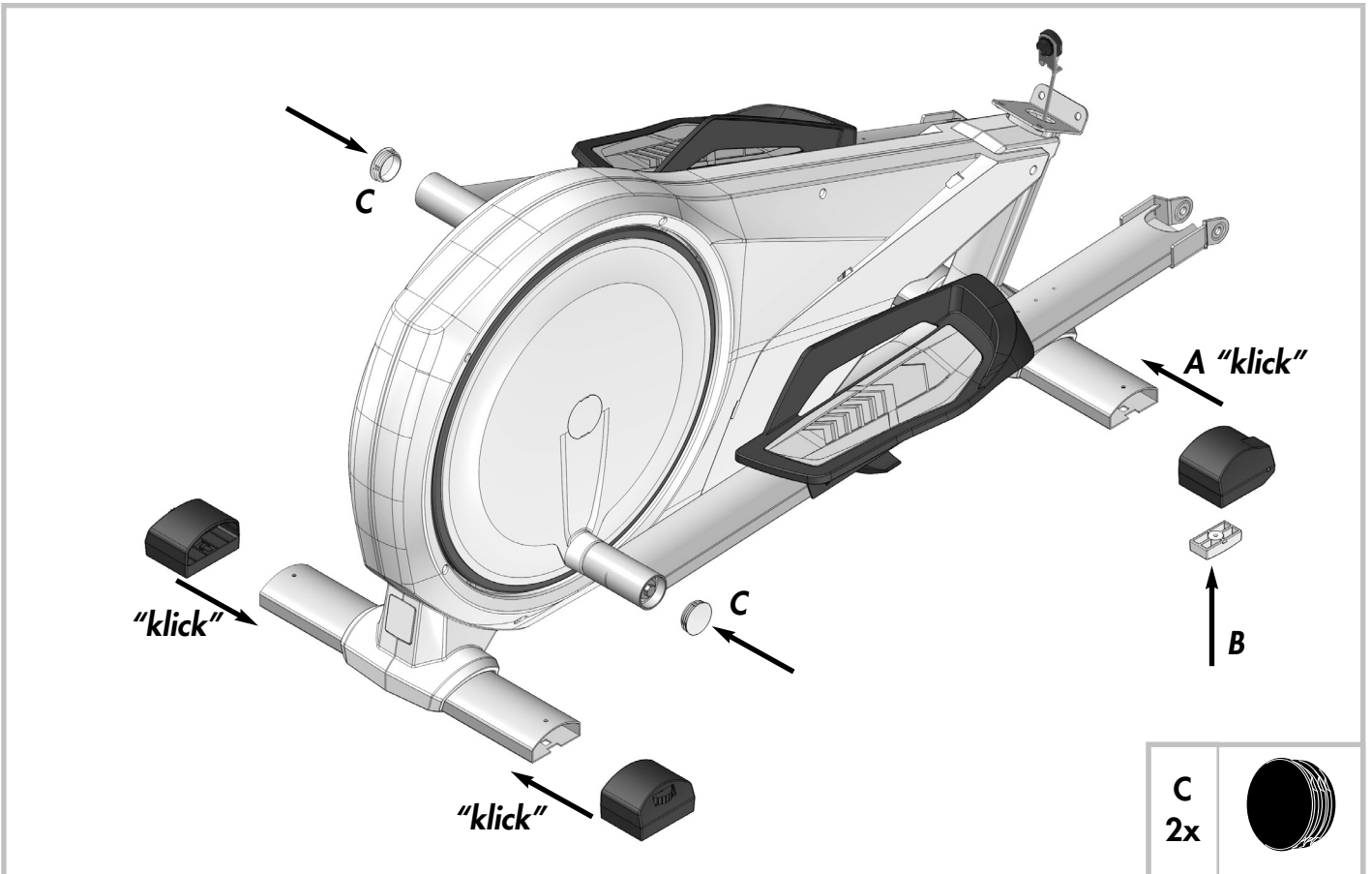



- D - Schraubverbindung regelmäßig kontrollieren.
- GB - The screwed connections must be controlled at regular intervals.
- F - Resserrer le raccord à vis à intervalles réguliers.
- NL - Schroefverbinding moet regelmatig opnieuw vastgedraaid worden.
- E - La atornilladura debe ser apretada con regularidad.
- I - Il collegamento a vite va riserrato ad intervalli regolari.
- PL - Połączenie śrubowe musi być regularnie dokręcane.
- CZ - Šroubové spojení pravidelně kontrolujte.
- P - Verifique regularmente as uniões roscadas.
- DK - Kontrollér skrueforbindelsen regelmæssigt.
- RUS - Регулярно проверяйте винтовое соединение.

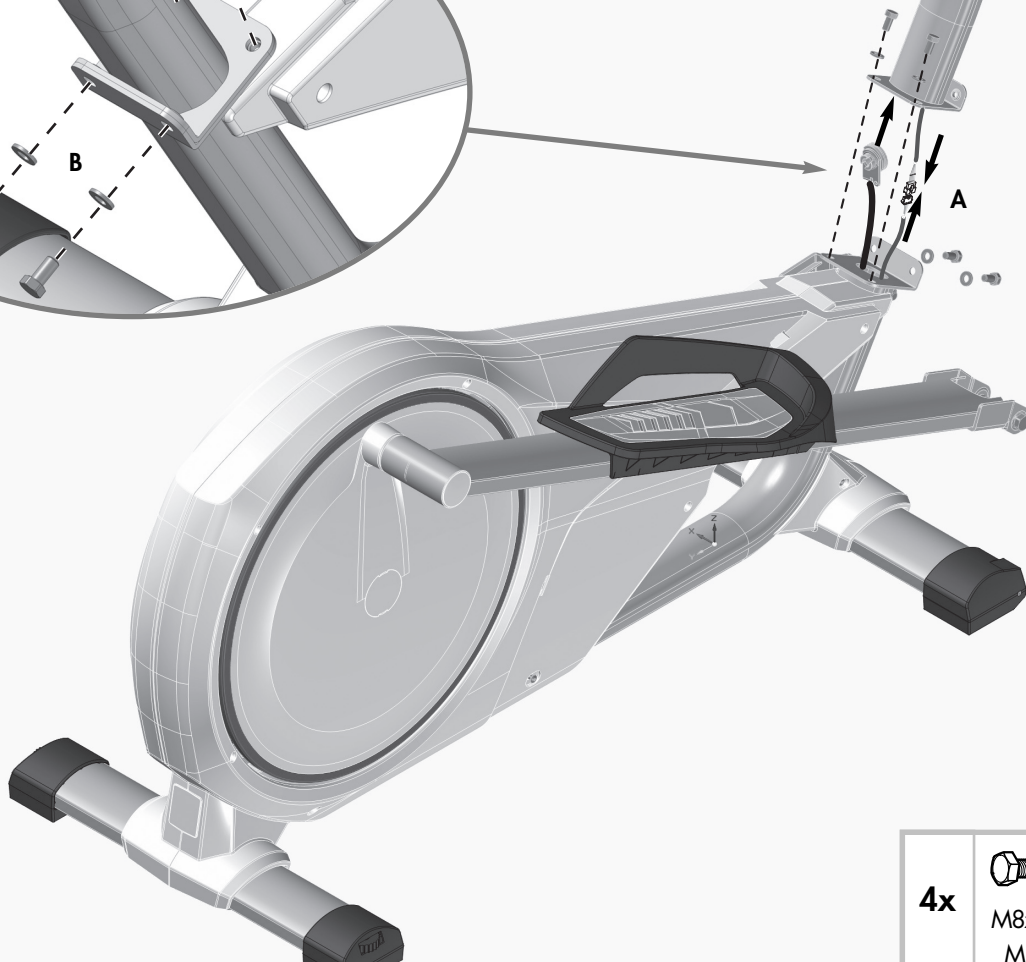
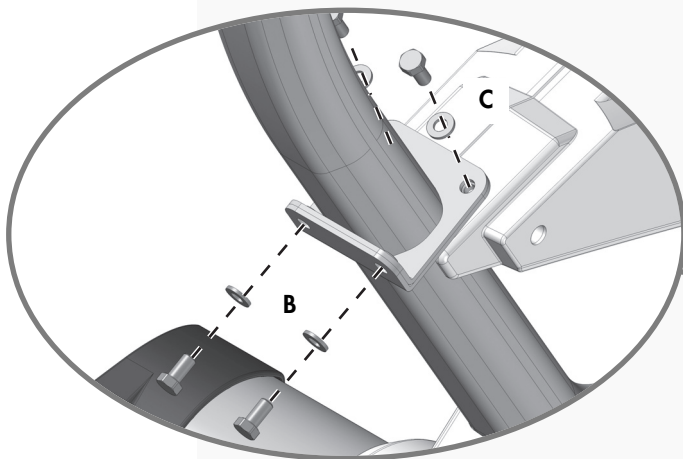
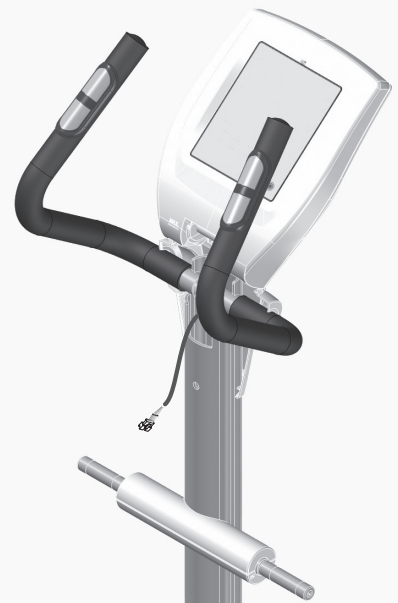

4x



M8x16 \varnothing 16x8,3
M = 20-25 Nm

4

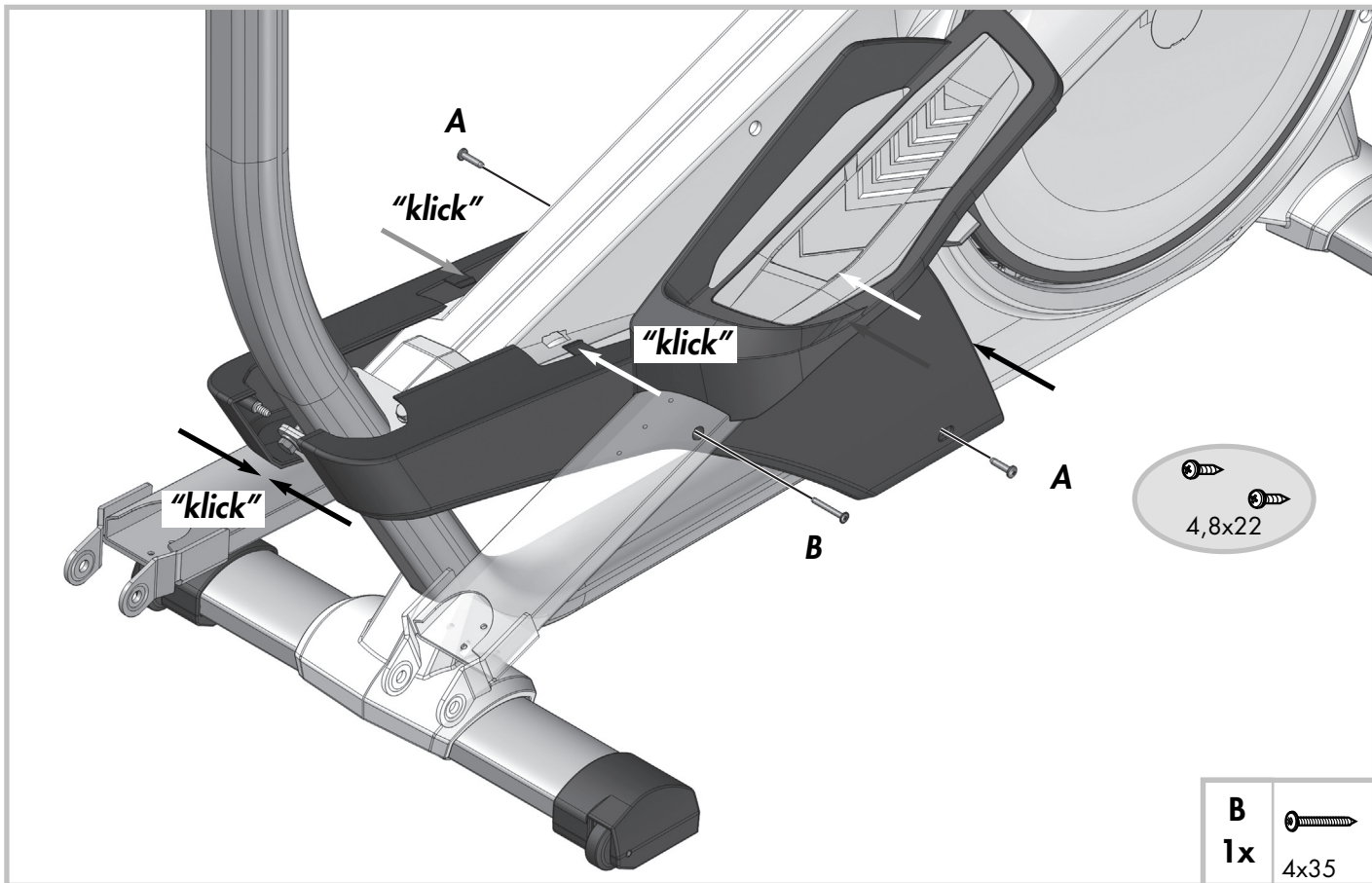

5

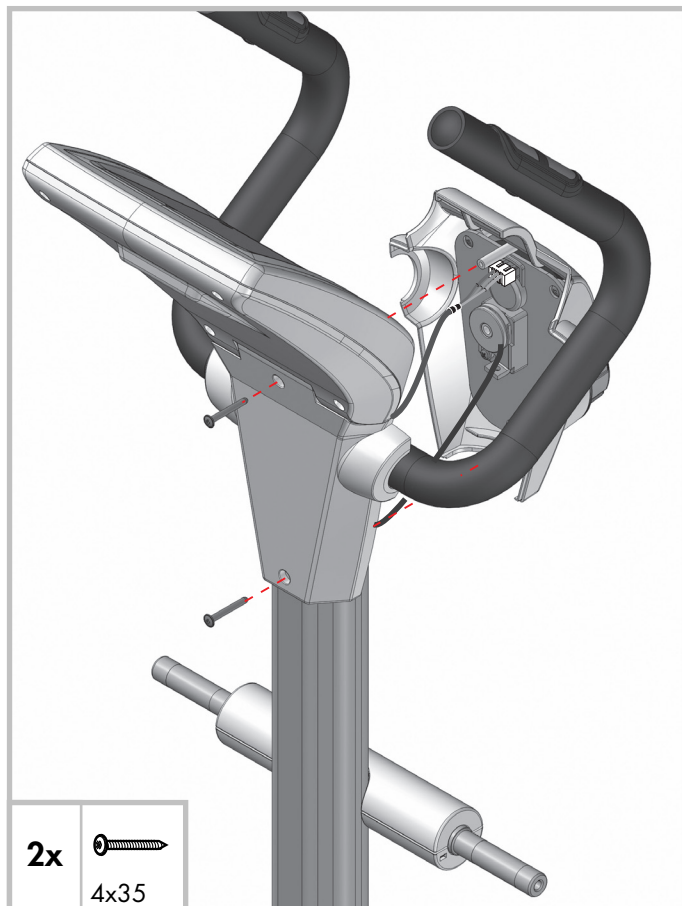
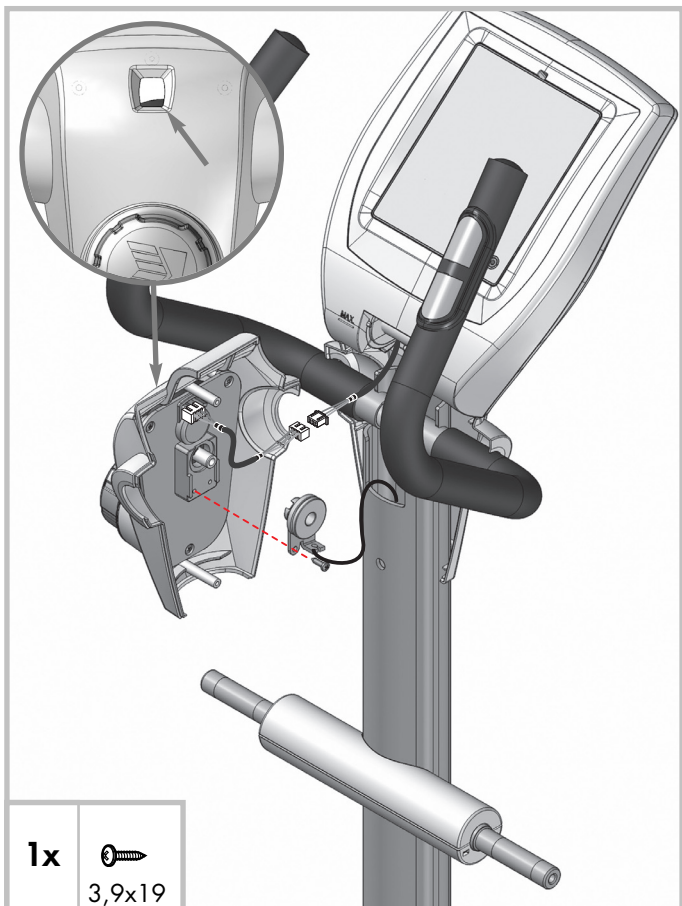

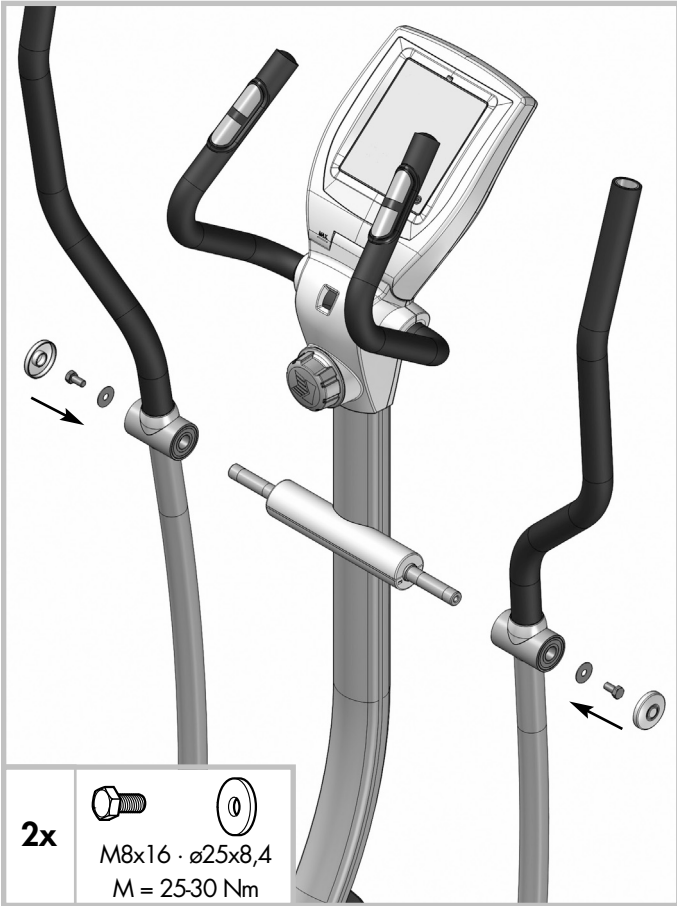

2x



M8x16 · ø25x8,4
M = 25-30 Nm



2x

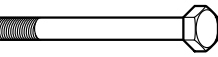

M 10 · ø18x11,3 · M10x80
M = 25-30 Nm

2x



3,9x19

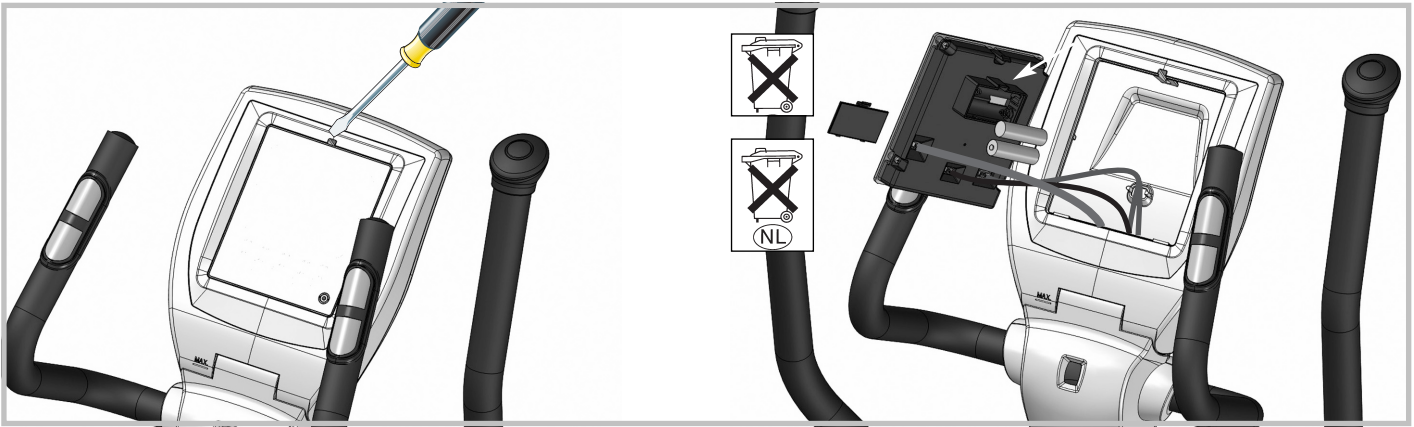

Eine schwache oder erloschene Computeranzeige macht einen Batteriewechsel erforderlich. Der Computer ist mit zwei Batterien ausgestattet. Nehmen Sie den Batteriewechsel wie folgt vor:

- Nehmen Sie den Batteriefachdeckel ab und ersetzen Sie die Batterien durch zwei neue vom Typ AA 1,5V.
- Achten Sie beim Einsatz der Batterien auf die Kennzeichnung im Batteriefachboden.
- Sollte es nach dem Wiedereinschalten zu Fehlfunktionen kommen, klemmen Sie die Batterien noch einmal kurz ab und wieder an.

Wichtig: Aufgebrauchte Batterien fallen nicht unter die Garantiebestimmungen.

Entsorgung von gebrauchten Batterien und Akkus.

Dieses Symbol weist darauf hin, dass Batterien und Akkus nicht mit dem normalen Hausmüll entsorgt werden dürfen.

Die Buchstaben Hg (Quecksilber) und Pb (Blei) unter der durchgestrichenen Mülltonne weisen zusätzlich darauf hin, dass in der Batterie/dem Akku ein Anteil von mehr als 0,0005% Quecksilber oder 0,004% Blei enthalten ist.

Falsches Entsorgen schädigt Umwelt und Gesundheit, Materialrecycling schont kostbare Rohstoffe.

Entfernen Sie bei der Stilllegung dieses Produktes alle Batterien/Akkus und geben Sie sie an einer Annahmestelle für das Recycling von Batterien oder elektrischen und elektronischen Geräten ab.

Informationen über entsprechende Annahmestellen erhalten Sie bei Ihrer örtlichen Kommunalbehörde, Entsorgungsbetrieb oder der Verkaufsstelle dieses Gerätes.

– GB – Battery change

A weak or an extinguished computer display makes a battery change necessary. The computer is equipped with two batteries. Perform the battery change as described below:

- Remove the lid of the battery compartment and replace the batteries by two new batteries of type AA 1,5V.
- When inserting the batteries pay attention to the designation on the bottom of the battery compartment.
- Should there be any misoperation after switching on the computer again, shortly disconnect the batteries once again and re-insert them.

Important: The guarantee does not cover worn-out batteries.

Disposal of used batteries and storage batteries

This symbol tells you that batteries and storage batteries must not be disposed of with the normal household waste.

The symbols Hg (mercury) and Pb (lead) underneath the crossed-out rubbish bin also tell you that the battery or storage battery contains more than 0.0005% mercury or more than 0.004% lead.

Improper disposal damages the environment and can damage people's

health. Recycling of materials conserves precious raw materials. When disposing of the appliance, remove all batteries and storage batteries from the product and hand them over to the collection point for the recycling of batteries or electrical or electronic appliances. Information about the appropriate collection points can be obtained from your local authorities, your waste disposal team or in the outlet where this appliance was sold.

– F – Changement de piles

Un affichage de l'ordinateur faible ou éteint impose un changement des piles. L'ordinateur est équipé de deux piles. Effectuez le changement comme suit:

- Enlevez le couvercle du logement des piles et remplacez-les par deux piles neuves du type AA 1,5V.
- Veillez au marquage au fond du logement lors de la mise en place des piles.
- En cas de dysfonctionnement après la remise en marche, enlevez brièvement les piles et remettez-les ensuite.

Important: Les piles usées sont exclues des dispositions de garantie.

Elimination des piles et des accumulateurs usagés.

Ce symbole indique que les piles et les accumulateurs ne doivent pas être éliminés avec les déchets ménagers ordinaires.

Les lettres Hg (mercure) et Pb (plomb) situées sous la poubelle barrée indiquent en outre que la pile/l'accumulateur contient une part de plus de 0,0005 % de mercure ou de 0,004% de plomb.

Une mauvaise élimination nuit à l'environnement et à la santé ; le recyclage des matériaux épargne de précieuses matières premières. Enlevez toutes les piles/accumulateurs lorsque ce produit est mis hors service et remettez-les dans un dépôt afin de recycler les piles ou les appareils électriques et électroniques.

Vous trouverez des informations concernant les dépôts correspondants auprès de votre commune, d'une entreprise de traitement ou dans le point de vente où l'appareil a été acheté.

– NL – Verwisselen van de batterijen

Een zwakke of weggevalle computerweergave maakt een batterijwisseling noodzakelijk. De computer werkt op 2 batterijen. Verwisselen van de batterijen gaat als volgt:

- Verwijder het deksel van het batterijenvak en vervang de batterijen door twee nieuwe van het type AA 1,5V.
- Let bij het verwisselen van de batterijen op de tekens in het batterijenvak.
- Treden er na het verwisselen nog foutieve functies op, haalt u dan de batterijen nogmaals uit het vak en duw ze weer terug.

Belangrijk: batterijen vallen niet onder de garantie.

Verwijderen van gebruikte batterijen en accu's.

Handhabungshinweise

- GB - Handling
- E - Aplicación
- CZ - Pokyny k manipulaci
- RUS - Указания по обращению

- F - Utilisation
- I - Utilizzo
- P - Notas sobre o manuseamento

- NL - Handleiding
- PL - Zastosowanie
- DK - Håndtering

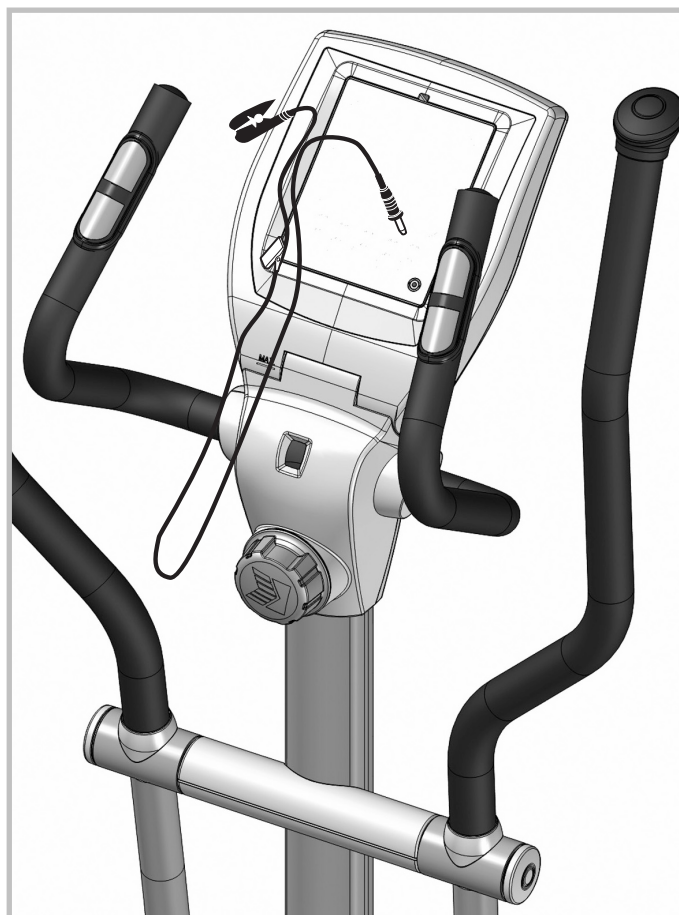
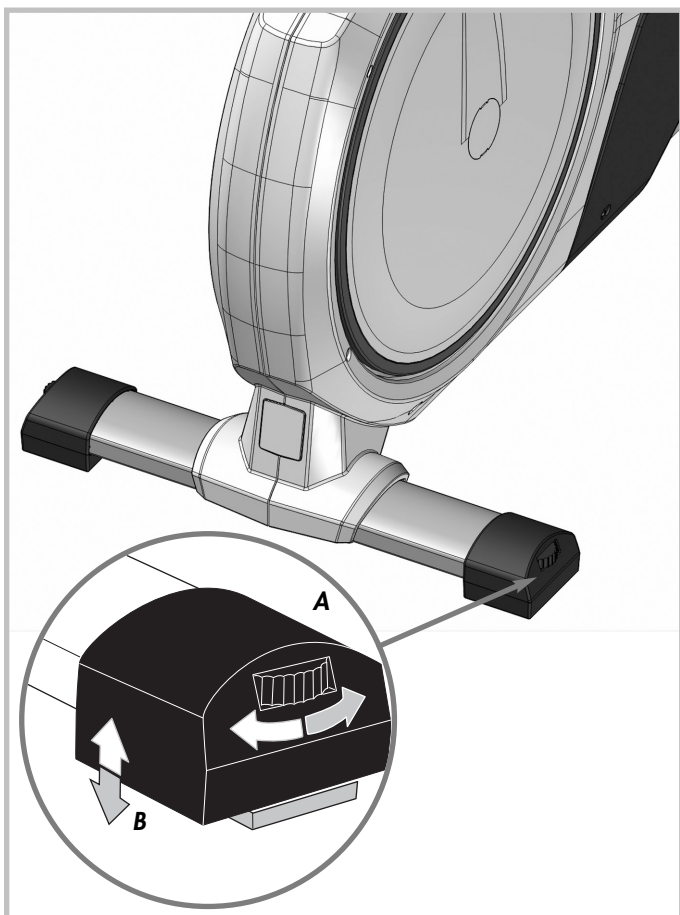
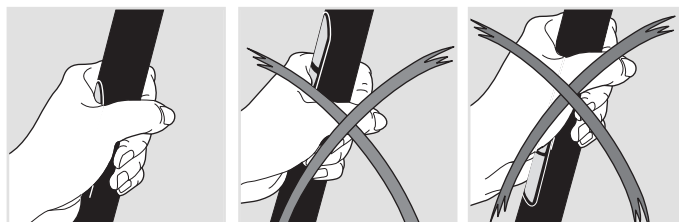
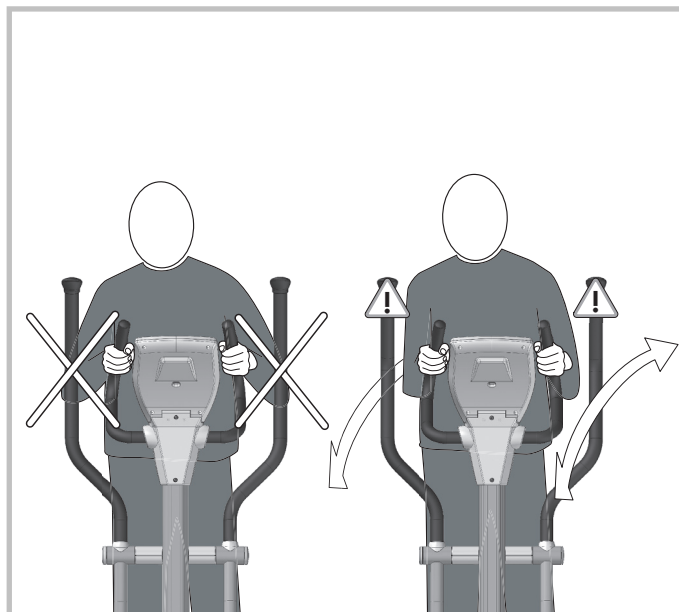

Handhabungshinweise

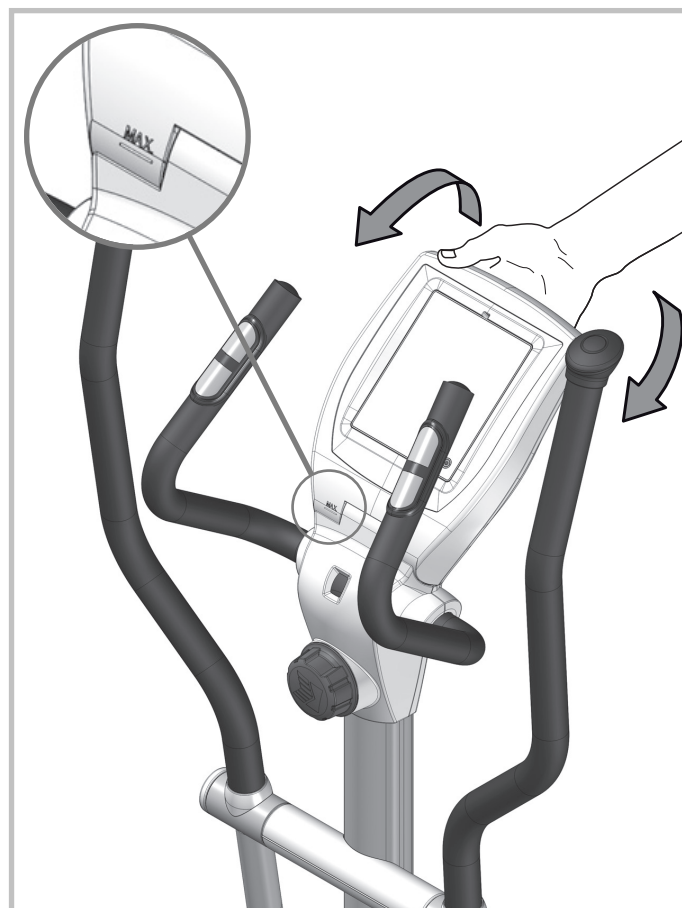
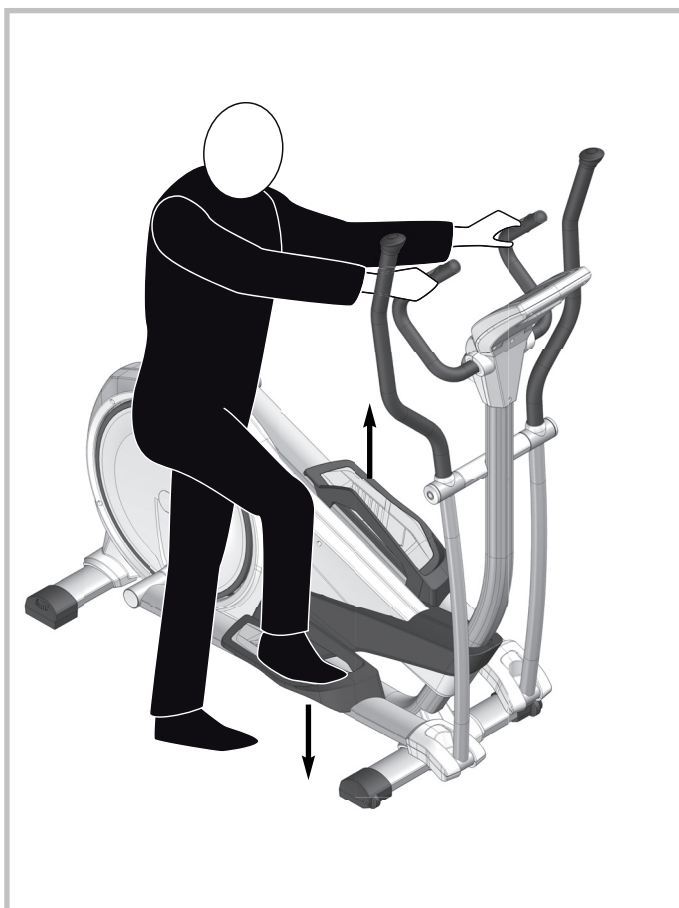

Ersatzteilbestellung

- GB - Spare parts order
 - E - Pedido de recambios
 - CZ - Objednání náhradních dílů
 - RUS - Заказ запчастей

- F - Commande de pièces de rechange
 - I - Ordine di pezzi di ricambio
 - P - Encomenda de peças sobressalentes

- NL - Bestelling van reserveonderdelen
 - PL - Zamówienie części zamiennych
 - DK - Bestilling af reservedele

07650-000		
Unix M		
①	1x	94600722
②	1x	94600723
③	1x	70129374
④	1x	94600212
⑤	1x	67000653
⑥	1x	70133522
⑦	1x	70127839
⑧	1x	94318315
⑨	1x	67000838
⑩	1x	94600215
⑪	1x	67000967
⑫	1x	94600216
⑬	2x	10100098
⑭	1x	94600724
⑮	2x	94600218
⑯	1x	94600234
⑰	1x	94600235
⑱	1x	91140381
⑲	1x	94600241
⑳	1x	25635052
㉑	1x	25615060
㉒	1x	94313513
㉓	1x	67000936

07650-000		
Pos.- Nr.		Unix M
②4	1x	1701399A
②5	1x	67000664
②6	1x	94318313
②7	1x	94600225
②8	1x	94600224
②9	2x	70130112
③0	2x	94600725
③1	1x	94600227
③2	2x	70129511
③3	1x	94600228
③4	1x	67005127
③5	1x	10900092
③6	1x	94600229
③7	1x	10900091
③8	1x	94600230
③9	1x	91180488
④0	2x	94600231
④1	2x	97200256
④2	1x	94600507
④3	1x	70133523
④4	1x	70129531
④5	1x	94318483

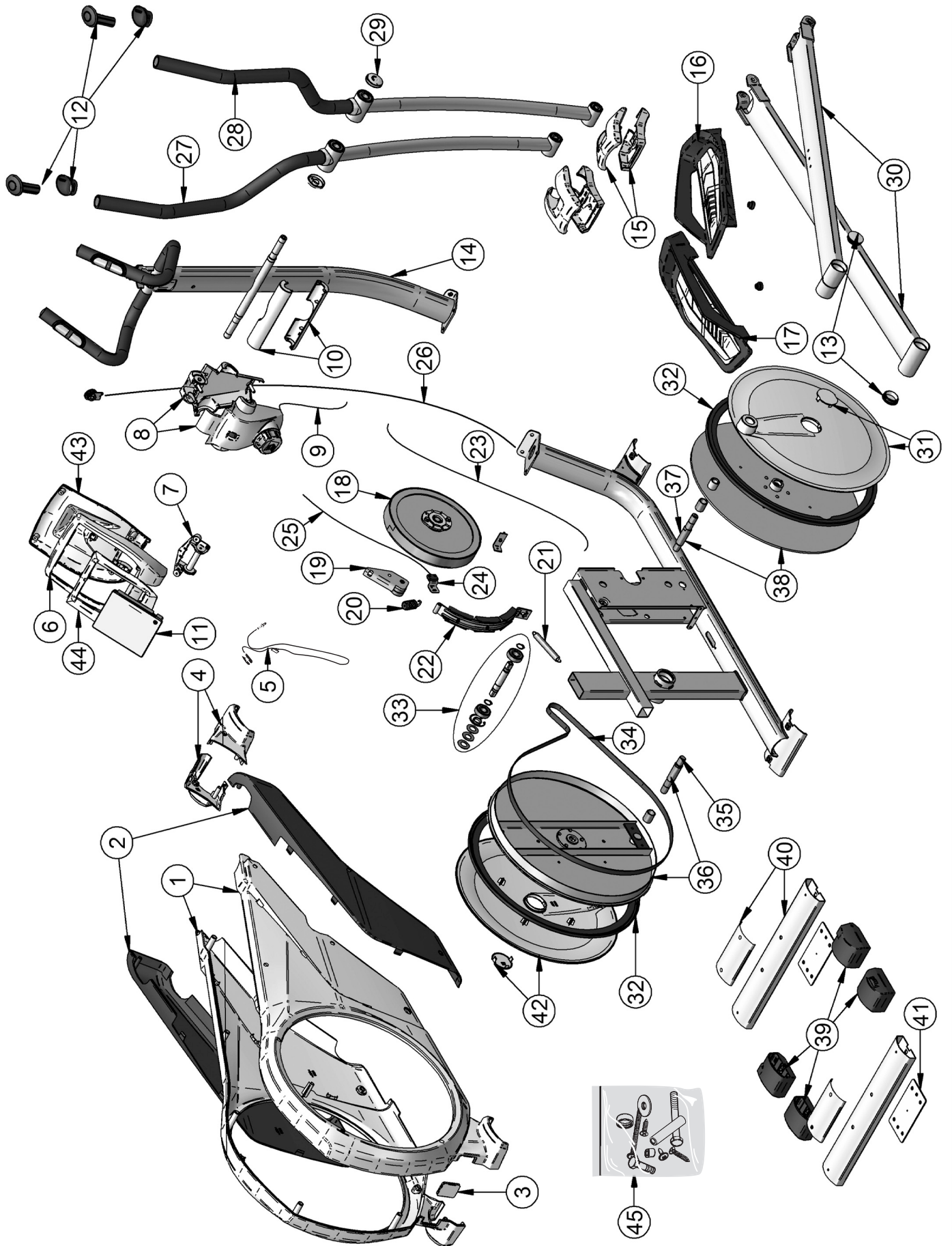

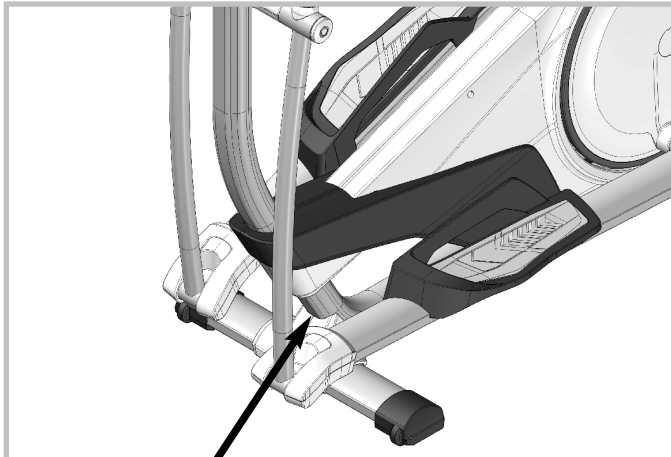





- D - Beispiel Typenschild - Seriennummer
- GB - Example Type label - Serial number
- F - Exemple Plaque signalétique - Numéro de série
- NL - Bij voorbeeld Typeplaatje - Seriennummer
- E - Ejemplo Placa identificativa - Número de serie
- I - Esempio Targhetta tecnica - Numero di serie
- PL - Przykłady Tabliczka identyfikacyjna - Numer serii
- CZ - Příklad typového štítku - sériové číslo
- P - Exemplo placa de características - número de série
- DK - Eksempel type label - serienummer
- RUS - Пример заводской таблички с серийным номером
- D - Geben Sie bei Ersatzteilbestellungen bitte die vollständige Artikelnummer, die Ersatzteilnummer, die benötigte Stückzahl und die Seriennummer des Gerätes an.
- GB - When ordering spare parts, always state the full article number, spare-part number, the quantity required and the S/N of the product.
- F - En cas de commande de pièces de rechange, nous vous prions de mentionner la référence article, le numéro de pièce de rechange, la quantité demandée et le numéro de série de l'appareil.
- NL - Vermeld bij de onderdelenbestellingen a.u.b. het volledige artikelnummer, het onderdeelnummer, het benodigde aantal en het serienummer van het apparaat.
- E - Indicar con los pedidos de piezas de repuesto el número completo del artículo, el número de la pieza de repuesto, las unidades solicitadas y el número de serie del aparato.
- I - Per l'ordinazione di parti di ricambio indicate il completo numero di articolo, della parte di ricambio, il numero di unit necessario nonchè il numero di serie dell'apparecchio.
- PL - Przy zamawianiu części zamiennych proszę podawać kompletny numer artykułu, numer części zamiennej i numer serii urzqdzenia.
- CZ - Při objednání náhradních dílů prosím udejte úplné číslo zboží, číslo náhradního dílu, potřebný počet kusů a sériové číslo přístroje.
- P - Ao encomendar peças sobressalentes, por favor indique o número completo do artigo, o número da peça sobressalente, o número de unidades necessárias e o número de série do aparelho.
- DK - Ved bestilling af reservedele skal du altid opgive det fuldstændige artikelnummer, nummeret på reservedelen, det ønskede antal og maskinens serienummer (se Håndtering).
- RUS - Оформляя заказ на запчасти, указывайте полный артикульный номер, номер запасной детали, необходимое количество и серийный номер устройства.

Zubehörbestellung

- GB - Accessories
- NL - Accessoires
- I - Accessori
- CZ - Příslušenství
- DK - Tilbehør
- F - Accessoires
- E - Accesorios
- PL - Akcesoria
- P - Acessórios
- RUS - Аксессуары

		07937-600
		07937-650
		07937-700
	100x 75 cm	07937-100
	140x 80 cm	07937-200
	250 x 70 cm	07929-300
	220x110 cm	07929-400